

# Expressions of National Identity in the Modern Architecture of Kazakhstan: The Case of Kazakh Stalactite-Arrow-Shaped Arcade

Askar Kussainov<sup>1</sup>, Bekrimzhan Glaudinov<sup>1</sup> & Ravil Muksinov<sup>2</sup>

<sup>1</sup>Department of Architecture  
International Educational Corporation (KazGASA campus)

<sup>2</sup>Department of Architecture  
Kyrgyz-Russian Slavic University  
Email for correspondence: askarkussainov443@gmail.com

## Abstract

The elements of the architectural objects of modern Kazakhstan are living evidence of the influence of the system of caravan roads of the Great Silk Road that crossed the territory of Kazakhstan in ancient times. Among them, the decorative structure "Kazakh stalactite-arrow-shaped arcade" is a unique project.

The purpose of this study is to identify the signs of national identity in the architecture of the project "Kazakh stalactite-arrow-shaped arcade" and to identify the factors influencing the development of national architecture in Kazakhstan. It is analyzed in this paper for the first time as an original artistic idea. The study of this architectural object allows tracing the originality of Central Asian architectural solutions, such as the pointed arched vault, domed structures, stalactites, and ornaments.

The article employed the method of analysis of published research to investigate the cultural influences, and spatial organization of the "Kazakh stalactite-arrow-shaped arcade". It also employed observations and image analysis to study the architectural elements.

The paper reveals the trends common to the region in the establishment and development of national architecture. It identifies the objective patterns of the establishment and development of architecture, and offers a theoretical basis for the implementation of progressive architectural and construction traditions in modern design practice. It also contributes to pedagogical work, in the development of diploma courses related to national architectural monuments of the Republic of Kazakhstan.

**Keywords:** Architecture and construction; Architectural orders; Experience of architects; Globalisation; Traditions in architecture; National culture; Cultural features; Architectural heritage.

## Introduction

Architectural structures reflect the cultural characteristics and values of a community, since architecture is a by-product of geography, traditions, beliefs, customs and behaviour of people and their history. In this sense, architectural objects can denote certain cultural aspects and have symbolic references to the history of a region (Idak, 2021; Yeboah et al., 2022). They

become a physical manifestation of these immaterial concepts that reveal the identity of a person or society. The created spaces evoke a sense of belonging to a certain group or nation. They make people experience their existence meaningfully, thereby helping them to remember who they are (Pandya, 2020). Architecture of a region acts as a mirror of national temperament. Each building reflects the character of the nation, telling people about themselves (Doszhan, 2023). For a developing country, the national architectural identity is vital, because it acts as a symbol of unity and is able to instill a sense of pride and affection for the country (Mosunov, 2017).

Preserving identity and the special characteristics of a place requires a deep understanding of existing natural systems and immersion in time-tested cultural reactions to the assets and liabilities of this environment, which contain the essence of sustainability (Quek, 2012). As a result of multifaceted interactions and human ability to adapt to the environment, each region develops unique architectural characteristics that distinguish it from any other place, forming the basis of its identity (Doszhan, 2022; Kharytonova & Bielova, 2021). The Oxford English Living Dictionary defines the term "identity" as a set of characteristics that determine who or what a person/object is. Created by people and for people, architecture is constantly evolving and changing over time to meet the needs of society in harmony with the environment (Salman, 2018).

Most modern cities are losing their identity due to imported global styles and techniques that do not correspond to the environment and do not reflect the uniqueness of the national culture. McLennan (2004) notes: "A simple look at most of our communities being built today shows that we have really lost respect for the place". Globalisation has the strongest possible impact on architecture: through the dissemination of concepts by reputed architects, the organisation of international architectural bureaus or the widespread dissemination of trans-spatial methods of digital design. Free access to the exchange of visual images of countless projects around the world, and an abundance in global exports of building materials and components have led to a sharp increase in the level of labour mobility among the architects (McLennan, 2004).

The purpose of this research is to recognise the elements of national identity within the architecture of the "Kazakh stalactite-arrow-shaped arcade" and identify the factors that have shaped the development of national architecture. The objectives of the paper are:

- to uncover trends that are common to the region in the establishment and evolution of national architecture.
- to identify the objective patterns in the establishment and development of architecture and
- to provide a theoretical foundation for incorporating progressive architectural and construction traditions into modern design practices.

## Literature Review

By analysing the course of the world historical development of architecture, it can be found that it was not the Greek civilization that was the inventor of architectural orders (Thoenes & Byatt, 2017). In modern perception, architectural orders came into the practice from the scientific architectural and construction doctrines of Roman architects and Italian architects such as Palladio and Vignolla (Wittkower, 1945). They idealized and systematized them in their writings. The Roman Empire used the experience of Greek architects, although, the Romans used architecture in a way and on a scale that was largely alien to the Greeks (Garland, 2017). Those, in turn, used the achievements of "pre-Greek" tribes, such as the Dorians (Herzog, 2017; Hamed, 2017).

On the example of the orders of Cretan, ancient Egyptian architecture, similarities of the beam-and-column system are found (Kolosova & Vadyaeva, 2020), but differ in its external stylistics. In the ancient Egypt, the capital of the columns looked like papyrus in a bundle, and among the people of the Cretan culture, they look like lotus buds (Craven, 2021). In the Roman Empire, all types of Greek orders are also used, but in a significantly revised and reinterpreted form, and in a later period in an eclectic form, without observing previously accepted

proportions (Della Torre, 2020; Pires, 2021). In the Roman Empire, architectural order is used as decoration of arched structures, and not as a structural element of the beam-and-column system. Consequently, in each historical epoch, the dominant civilization borrowed the achievements of the conquered people, based on the main design features, however, outwardly stylised under the cultural characteristics of the victorious people (Dayaratne, 2012).

National identity in the architecture of Kazakhstan can develop based on generally accepted achievements of world architecture, where it can be improved and adapted in a peculiar Kazakh way, but meeting modern requirements of the time (Fisher, 2016). This should not be perceived as something inappropriate or some kind of plagiarism (Hatem Galal, 2016). In confirmation of this, during the Soviet period, truly memorable and iconic objects associated with Kazakh culture were created, with which a new Kazakh architectural school stood out (Jashari-Kajtazi & Jakupi, 2017). Objects in the city of Almaty such as the Palace of the Republic, the Hotel Kazakhstan, the "Arman" cinema, the Circus Building, the Wedding Palace, the Central Museum, the Hardware and Studio Complex, the Wellness and Bath complex "Arasan" and many others like them are the result of creative searches, figuratively referring to the historical architectural heritage of the Turkic-speaking people of Central Asia. However, they were modern interpretations of regional artistic and plastic features using new achievements in construction and new challenges in architecture. Such an innovative approach leads the image of buildings to artistic references of the memorial architecture of majestic mausoleums (Baitenov et al., 2019).

Kazakhstan is a striking example of a country with historically developed cultural diversity and is inhabited by various ethnic and religious groups (Abdrasilova & Kozbagarova, 2018; Priemets et al., 2018). Hence, it raises issues of national identity as manifested in the built-structures. Among them, one experimentally indicative architectural sample exists which has been based on the regional principles of architectural shaping, and representing an independent art object performing a decorative function, created exclusively for landscaping (Farhan et al., 2020).

According to Mosunov (2017), the original project "Kazakh stalactite-arrow-shaped arcade" has been implemented within the framework of the Kazakh programme "Rukhani Zhangyru" in order to preserve, strengthen, and develop the national identity of Kazakhstan. Built in Almaty in 2020 in front of the Main academic building of the leading Academy of Architecture and Civil Engineering, this project implies the revival and support of the development of national culture of Kazakhstan. Academic Professor B.A. Gludinov was the author of the idea to use the symbol of this university as the basis of the architectural image. Detailed and artistic implementation of the project work belongs to the Master Architect A.M. Kusainov. It has an author's certificate and a patent for an industrial design registered in the unified state register of the National Institute of Intellectual Property of the Republic of Kazakhstan. Indeed, the implementation of this project can become a generalized example of the main artistic technique for the establishment of a recognized tool for constructing the Kazakh identity in modern architecture.

## Research Methods

In this study, the problem of architectural identity refers to the region of Kazakhstan, which is a striking example of a country with historically developed cultural diversity and is inhabited by various ethnic and religious groups. This case study was limited to one experimentally indicative architectural sample, as a practical result, based on the regional principles of architectural shaping, and representing an independent art object performing a decorative function, created exclusively for landscaping.

The research employed observations examine the "Kazakh stalactite-arrow-shaped arcade", a decorative structure in a regionally innovative style in the form of a monument, interpreting in architectural and artistic language, the composition of three simple pencils. This method involved visually examining the architectural structure and documenting its various elements, such as shape, materials, colors, and decorative features. Analysis of previously published scientific research related to the region and its architectural heritage provided

valuable information about the cultural, social, and religious influences that shaped the "Kazakh stalactite-arrow-shaped arcade". In addition, these research helped establish the significance and context of the monument. Creating detailed documentation, including measurements, sketches, and photographs served as a visual record of the monument. Image analysis helped study the spatial organization and the structural elements.

### Findings and Discussion

"Kazakh stalactite-arrow-shaped arcade" has a decorative function and is considered as an independent art object, and a small architectural form created for aesthetic enrichment of the landscaping of the territory or landscape (Fig. 1). The semantic meaning of the "Kazakh stalactite-arrow-shaped arcade" is a memorable symbolization of the facade of the value of the main tool of the creative work of modern Kazakh architects: that is, pencils. Indeed, it is also the symbol-logo of the Kazakh Leading Academy of Architecture and Civil Engineering in Almaty, Kazakhstan (KazGASA). Any closest analogues of the monument "Kazakh stalactite-arrow-shaped arcade" in terms of semantic meaning and design configuration have not been found.

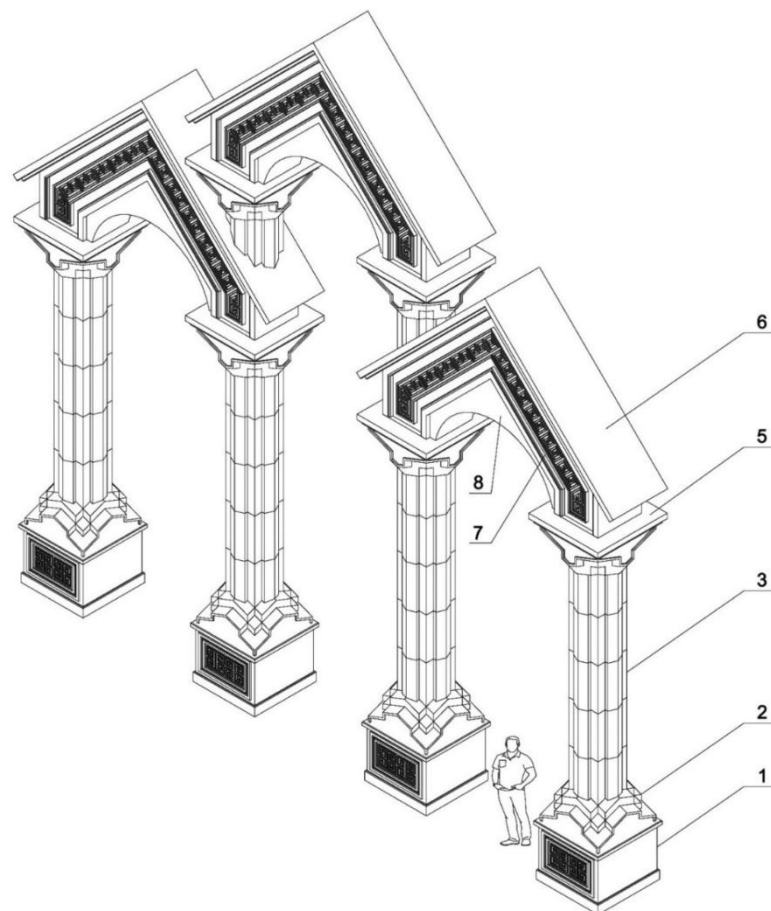

**Fig. 1:** General view: 1 – curbstone pedestal with a rosette of Kazakh figured ornament; 2 – stalagmite base of the column; 3 – star-shaped column trunk in plan view; 4 – stalactite column capital; 5 – arrow-shaped arch; 6 – moulding of Kazakh figured ornament; 7 – arched vault

Source: prepared by the authors

"Kazakh stalactite-arrow-shaped arcade" is a symmetrical architectural and artistic arcaded composition formed not just according to the classical principles of architectural and plastic shaping, but also from architectural parts and elements stylised to Kazakh motifs in the form of a set of products made of marble-coloured fibrous concrete and light grey granite (Figs 2-5). The set of these products consists of 3 main parts.

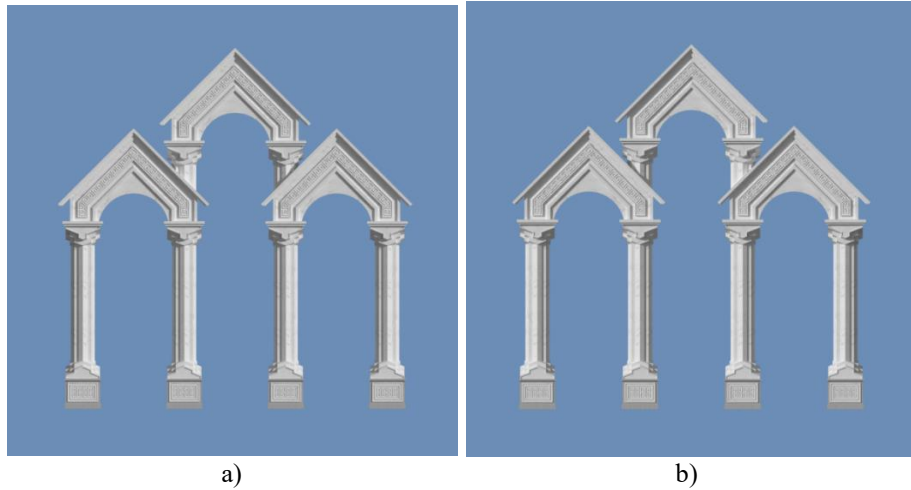

**Fig. 2:** Kazakh stalactite-arrow-shaped arcade: a) front view; b) rear view  
Source: prepared by the authors

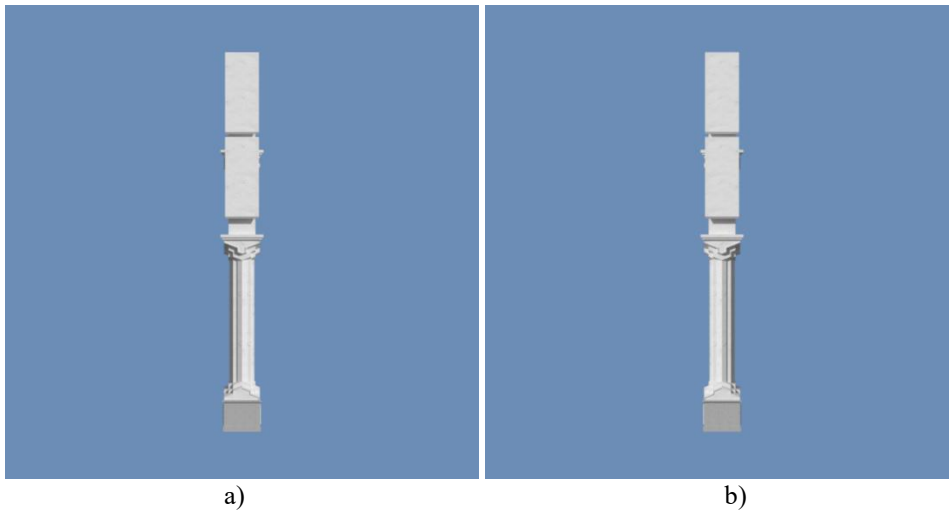

**Fig. 3:** Kazakh stalactite-arrow-shaped arcade: a) side view – left; b) side view – right  
Source: prepared by the authors

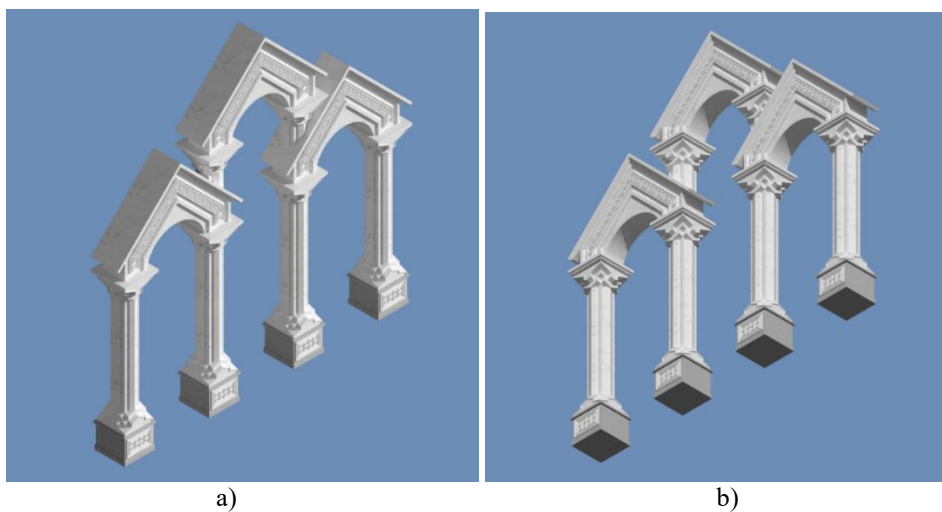

**Fig. 4:** Kazakh stalactite-arrow-shaped arcade: a) general view – in isometric view from above;  
b) general view – in isometric view from below  
Source: prepared by the authors



**Fig. 5:** Kazakh stalactite-arrow-shaped arcade  
Source: prepared by the authors

*Part 1.* Pedestals, which are square in cross-section pedestals, sheathed in grey granite with a grey granite slab covering over it (Fig. 6). The base of the curbstones is reinforced along the perimeter with a granite skirting ledge, also made of grey granite. The two front facades of the curbstones are supplemented with inserts of the authorial composition of figured ornament framed in fibrous concrete.



**Fig. 6:** Curbstone pedestal with a rosette of Kazakh figured ornaments and a stalagmite base of the column  
Source: prepared by the authors

*Part 2.* Colonnade, original interpretation of the stalactites of medieval architecture of Central Asia (Fig. 2). The column bodies, made entirely of fibrous concrete, in turn also consist of 3 parts:

- the base of the column, in the form of stalagmites, forming the image of references to the silhouettes of the memorial architecture of Kazakhstan;
- the trunk of the column, in the cross section of which the traditional Turkic eight-pointed star is symbolically taken as the basis;
- capitals in imitation of stalactites, resembling fragments of the domed interiors of the mausoleum architecture of Kazakhstan during the reign of the Karakhanids.

*Part 3.* Entablature consisting of stylised combined arrow-shaped arches crowning a colonnade of 4 full columns and 2 half-columns. The figured bend of the pointed arches at 45 degrees is decorated with a moulding of the original figured ornament, the module of which resembles the ram's horns in silhouette (Fig. 7).



**Fig. 7.** Stellate trunk of the column, stalactite capital, and the arched roof with a moulding of Kazakh ornament

Source: prepared by the authors

This set of products is sheathed with a combined earthquake-resistant frame made of monolithic reinforced concrete up to the height of the level of the location of the column capitals. Above this mark, installation is carried out on a metal spatial frame. The foundation for the frame consists of monolithic reinforced concrete stepped slabs, which are laid at a depth of one and a half meters from the level of the upper covering of the ground. The coordination axes of the load-bearing elements are placed on one straight transverse axis with a step of 3.2 meters.

Relative to the general compositional structure, a framing with four pedestals is located along this step, above which four full-length columns of the original innovative Kazakh order are erected. Further, in the entablature part, arrow-shaped arcades rest on two columns on both sides. On the inner slopes of these vaults, half columns grow in continuation, which in turn are crowned with a central similar arrow-shaped-arched vault pointing upwards. The overall composition forms a three-headed through portal.

The overall dimensions are equal to  $1.290 \times 11.180 \times 11.385$  (H) mm and are selected according to the golden section principle, considering a comfortable visual and psychological perception of the surrounding urban planning environment. All of the above regarding the "Kazakh stalactite-arrow-shaped arcade" is a completely original artistic and design solution of a set of industrial products. The artistic features described above are the highlighted essential features of the difference between the monument of the "Kazakh stalactite-arrow-shaped arcade".

## Conclusions

In comparison with the construction of the 20th century, modern mass architecture has become technically much more complex, but more primitive in an artistic and figurative context. Over the last quarter of the 21st century, an entire industry for the production of architectural unified goods has emerged, the digital revolution has introduced new construction methods. To consolidate the role of national identity in the architecture of Kazakhstan, it is necessary to achieve progress of its integration influence at every stage of the design process. It was established that even the choice of building materials can significantly influence the perception of an architectural object in determining geographical and cultural identification.

It was also defined that the combination of materials of local origin, considering natural and climatic features in the development of spatial planning solutions, some historical principles of architectural and artistic shaping and modern intelligent construction technologies can lead to a more economical, energy-efficient and aesthetic design and emphasize the regional character. Therefore, architectural researchers and practicing architects should consider the following evaluation criteria for determining regional architectural projects, or when designing new objects with regional characteristics: the nature of the environment, the traditions of the

region, climatic conditions, materials for construction, the impact on environmental ecology, political and economic conditions and, of course, the social needs of residents.

### Acknowledgements

The authors express their gratitude to the Honorary President of the Kazakh Leading Academy of Architecture and Civil Engineering, Chairman of the Board of Directors of the International Educational Corporation, Doctor of Technical Sciences, Professor Kusainov Amirlan Aidarbekovich for the opportunity for creative self-realisation and LLP "Unex maintenance Co." for sponsorship in the construction of the above-described author's architectural and artistic structure "Kazakh Stalactite-Arrow-Shaped Arcade", timed as part of the celebration of the 60th anniversary of architectural education of the Republic of Kazakhstan.

### References

- Abdrassilova, G., Kozbagarova, N. (2018). *Architecture of high-rise buildings as a brand of the modern Kazakhstan*. [https://www.e3s-conferences.org/articles/e3sconf/abs/2018/08/e3sconf\\_hrc2018\\_01009/e3sconf\\_hrc2018\\_01009.html](https://www.e3s-conferences.org/articles/e3sconf/abs/2018/08/e3sconf_hrc2018_01009/e3sconf_hrc2018_01009.html)
- Baitenov, E., Tuyakayeva, A., Abdrassilova, G. (2019). Medieval mausoleums of Kazakhstan: Genesis, architectural features, major centres. *Frontiers of Architectural Research*, Vol. 8(1), pp. 80-93.
- Craven, J. (2021). *About Persian and Egyptian types of columns*. [thoughtco.com/persian-and-egyptian-columns-4092509](https://thoughtco.com/persian-and-egyptian-columns-4092509)
- Dayaratne, R. (2012). Landscapes of nation: Constructing national identity in the deserts of Bahrain. *National Identities*, Vol. 14(3), pp. 309–327. <https://doi.org/10.1080/14608944.2012.702744>
- Della Torre, S. (2020). Italian perspective on the planned preventive conservation of architectural heritage. *Frontiers of Architectural Research*, Vol. 10(1), pp. 108-116.
- Doszhan, R. (2022). The question of being in Al-Farabi's legacy and its succession to modern science. *Interdisciplinary Cultural and Humanities Review*, Vol. 1(1), pp. 40–44.
- Doszhan, R. (2023). Multi-vector cultural connection in the conditions of modern globalisation. *Interdisciplinary Cultural and Humanities Review*, Vol. 2(1), pp. 27–32. <https://doi.org/10.59214/2786-7110-2023-2-1-27-32>
- Farhan, S., Akef, V. & Nasar, Z. (2020). The transformation of the inherited historical urban and architectural characteristics of Al-Najaf's Old City and possible preservation insights. *Frontiers of Architectural Research*. <https://journal.hep.com.cn/foar/EN/10.1016/j.foar.2020.07.005>
- Fisher, S. (2016). Philosophy of architecture. *The Stanford Encyclopedia of Philosophy*. <https://plato.stanford.edu/archives/win2016/entries/architecture/>
- Garland, R. (2017). *Ancient Roman architecture: Rome's most impressive buildings*. <https://www.thegreatcoursesdaily.com/ancient-roman-architecture/>
- Hamed, R.E. (2017). Harmonization between architectural identity and energy efficiency in residential sector (case of North-West coast of Egypt). *Ain Shams Engineering Journal*, Vol. 9(4), pp. 2701-2708.
- Hatem Galal. A.I. (2016). Regeneration of sustainability in contemporary architecture: Approach based on native function and activities to strengthen identity. *Procedia – Social and Behavioral Sciences*, Vol. 216, pp. 800–809.
- Herzog, T. (2017). *Ancient Greek architecture was profoundly influenced by the Ancient Near East*. <https://graduateway.com/ancient-greek-architecture-was-profoundly-influenced-by-the-ancient-near-east/>
- Idak, Yu. (2021). Establishment and development of morphology as a basic science and its potential in the theory of urban planning. *Architectural Studies*, Vol. 7(2), pp. 173–182. <https://doi.org/10.23939/as2021.02.173>

- Jashari-Kajtazi, T., Jakupi, A. (2017). Interpretation of architectural identity through landmark architecture: The case of Prishtina, Kosovo from the 1970s to the 1980s. *Frontiers of Architectural Research*, Vol. 6 (4), pp. 480–486.
- Kharytonova, A., Bielova, O. (2021). Life and death of new cities. *Architectural Studies*, Vol. 7(1), pp. 58–65. <https://doi.org/10.23939/as2021.01.058>
- Kolosova, I.I., Vadyaeva, D.A. (2020). Stages of development, formation and improvement of the design features of wood in the architecture of the countries of the Ancient World BC NS. *Bulletin of the Tomsk State University of Architecture and Civil Engineering*, Vol. 22(4), pp. 31-40.
- McLennan, J.F. (2004). *The philosophy of sustainable design: The future of architecture*, Kansas: Ecotone.
- Mosunov, I. (2017). *Program Rukhani Zhagyru Modernization of public consciousness*. <https://informburo.kz/stati/modernizaciya-soznaniya-nachalas-kak-ona-rabotaet.html>
- Murray, F. (2019). *A global history of architecture in the era of globalization*. <https://journals.openedition.org/abe/5702>
- Pandya, S. (2020). Architecture in national identities: a critical review. *National Identities*, Vol. 22(4), pp. 381–393.
- Pires, S. (2021). *5 classical buildings that chronicle the wonder of Ancient Greek architecture*. <https://mymodernmet.com/ancient-greek-classical-architecture-examples/>
- Priemets, O., Samoilov, K., Zayats, I., Kenessarina, Z., Yssembayeva, E. (2018). *Innovations in Kazakhstan's architecture*. <https://1library.net/document/4zplx17q-innovations-in-kazakhstan-s-architecture.html>
- Quek, R. (2012). Dramatic pre-emption in Singapore's National Theatre: Constructing national identity before an independent nation. *National Identities*, 14(3), 287–307.
- Salman, M. (2018). *Sustainability and vernacular architecture: Rethinking what identity is, urban and architectural heritage conservation within sustainability*. <https://www.intechopen.com/chapters/64381>
- Thoenes, C., Byatt, L. (2017). Architectural orders: Rebirth or invention? *Art in Translation*, Vol. 9(3), pp. 296-311.
- Wittkower, R. (1945). Principles of Palladio's architecture: II. *Journal of the Warburg and Courtauld Institutes*, Vol. 8, pp. 68–106.
- Yeboah, A.S., Carol, S., Fathi, A. (2022). Demographic challenges for the Caucasian race: What can the assimilation of cultures on the European continent lead to? *European Chronicle*, Vol. 7(4), pp. 5–13.